

MIFAB®

INTERCEPTORS

INTERCEPTORS

REMOVABLE INTERNAL COMPONENTS

MIFAB's single baffle system is removable. Others offer fixed baffles and internal parts that once corroded, compromise the entire interceptor. All of MIFAB's internal parts are removable. This allows for easier maintenance because nothing is fixed and all parts can be removed for maximum access to the inside for cleaning.

SINGLE BOLT

MIFAB's smaller interceptors (up to 25 GPM) have a single 5/8" diameter bolt to secure the lid to the body. Larger interceptors have four large bolts. Others offer screws/wing nuts that become stripped, rusted out, filled with grease/dirt and/or lost. They are also time consuming to remove. MIFAB's lids are easy to remove with the single bolt design, allowing for regular cleaning of the interceptor.

LID

All of MIFAB's interceptors are manufactured with a powder coated, electrostatically applied cathodic epoxy coating as a standard feature. They all have a non-skid tread plate pattern for maximum safety and are recessed into the frame to provide either in ground or above ground installation with the same interceptor.

POWDER EPOXY COATING

MIFAB's interceptors are manufactured with a powder coated, electrostatically applied cathodic epoxy coating as a standard feature for no additional charge. This ensures maximum wearing and resistance to corrosive cleaning agents.

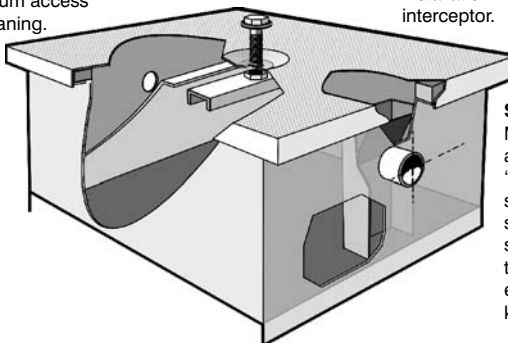

(MI-G ILLUSTRATED)

FEET ON BOTTOM

MIFAB's MI-G and MI-G-L grease interceptors have 1/2" feet on the bottom to elevate the interceptor from the wet ground to prevent corrosion.

DEEP SEAL TRAP

MIFAB's deep seal trap is covered by the lid. This permits easier roughing-in for the contractor since the interceptor is a perfect rectangle instead of a seven sided shape that requires extra work and time to install. It is also easier to clean out the deep seal trap with a MIFAB interceptor because one only needs to remove the lid and access is available to the body and the deep seal trap at the same time.

SEWER GAS STOPPER

MIFAB's grease interceptors are manufactured with a "sewer gas stopper" that is sealed on the top and both sides and extends into the static water level to eliminate the possibility of sewer gas entering the grease trap and kitchen area.

MIFAB INTERCEPTOR SELECTION GUIDE

There are three main types of interceptors: grease, oil and solids. Each of them requires different considerations for sizing, operation and maintenance. The information provided will help the specifier select the correct interceptor for the application. A detailed explanation of the major components and features of each type of interceptor is also provided.

Grease Interceptors

Grease, which also includes fats and oils, has historically caused problems in plumbing drainage systems. Grease easily adheres to the inner surface of most commonly used drainage piping material and over time will form into a hard crust as tough as baked clay. The rougher the inner surface of the pipe, the easier this adherence will occur. Grease is also a problem for sewage treatment plants as it taxes the bacterial process used to break down these complex compounds.

The purpose of a grease interceptor is to trap and store the suspended grease from the water passing through it. They are usually connected to kitchen sinks, floor drains, and any other plumbing fixtures in restaurants, hotels and institutions that discharge grease laden waste water. MIFAB's grease interceptors operate on the principle of separation by flotation.

As our environmental laws have become more restrictive and maintenance costs have increased, public sewer departments have responded by tightening the list of materials allowed to flow into their systems. Severe fines may be levied on those users found to be in violation. Grease that is removed from the drainage system as close as possible to its source and before it becomes contaminated with other material, can be sold to rendering companies and recycled into a variety of products. It can therefore become an economic asset rather than liability.

The specifying engineer should consider the following when specifying grease interceptors: construction / operation, flow control fitting, extensions, cover shrouds and draw-off valves, sizing, installation and maintenance.

Construction / Operation

All of MIFAB's grease, oil and solids interceptors are manufactured with 10 gage hot rolled steel that is welded together and coated with an electro-statically applied baked epoxy finish. The cover sealing gasket is manufactured with low durometer closed-cell neoprene with self-adhesive backing. The gasket is custom fitted to the interceptor body top rim ledge where it is an integral part of the body. Because of the gasket's thickness and density, it provides an ideal sealing environment for the lid. All of MIFAB's interceptors are supplied with the same gasket. All grease interceptors are supplied with a baffle system engineered to improve the grease/oil separation process. The baffle system is strategically located to direct inflow for maximum efficiency of the interceptor. Flow entering the interceptor is directed to the bottom by the baffle to avoid any disturbance of the previously accumulated surface layer of grease / oil in the device. The baffle also serves to reduce the velocity and surge of inflow, providing sufficient retention time for effective separation of the grease. The grease rises to the surface for manual or draw-off removal and the baffle is easy to remove for cleaning. The waste water is now relieved of over 90% of the fats, oils and greases and continues to flow through the interceptor into the drainage system. Many MIFAB grease interceptors bear the PDI (Plumbing and Drainage Institute) seal. This seal on MIFAB's grease interceptors proves that the designs and ratings marked on the interceptor have met or surpassed all standards established by PDI. All of MIFAB's PDI approved grease interceptors are supplied with external, vented flow control fittings to ensure maximum performance. A detailed description of flow control fittings is on page ii.

Design and dimensions are subject to modification. Prices do not include applicable taxes.

Visit www.mifab.com for the most recent product information.

MIFAB, Inc., 1321 West 119th Street, Chicago, Illinois 60643-5109, USA

Toll Free 1-800-465-2736, Fax 773-341-3049

All sales subject to MIFAB's Terms and Warranties. Please refer to inside front cover.

MIFAB FLOW CONTROL FITTING GUIDE

FLOW CONTROL FITTING APPLICATION: Flow control fittings are furnished at no extra cost with all MIFAB® MI-G, MI-G-L, MI-G-SD MI-G-SDH and MI-G-L-SDH grease interceptors. They are essential to achieve maximum efficiency.

FLOW CONTROL FITTING DESCRIPTION: Flow control fittings insure 90% or more grease retention efficiency of the interceptor. When consideration isn't given to the flow rate of the waste water to be handled, the actual flow rate through the interceptor usually exceeds its rated maximum. With such flow rate, the interceptor would be overloaded. Retention time within the unit would not be sufficient for maximum separation. The result would be low efficiency, and pollutants left in the waste water would pass through the interceptor, making the installation less than effective. When the flow is controlled by use of a MIFAB® flow control fitting so that it can never exceed the maximum rating of the interceptor, and the interceptor is cleaned on a regular basis, the maximum pollutant retention efficiency will be achieved and maintained.

All flow control fittings are built with an air intake and should be connected to the vent stack or vent not lower than the flow level of the highest drain serviced or terminated in a return bend at the same elevation outside of the building. A vented flow control fitting improves the efficiency of the grease interceptor by introducing air into the body of the interceptor. As the air bubbles rise to the surface, they are coated with grease. This process brings grease to the surface faster, and, as a result, increases the efficiency.

INTERCEPTORS

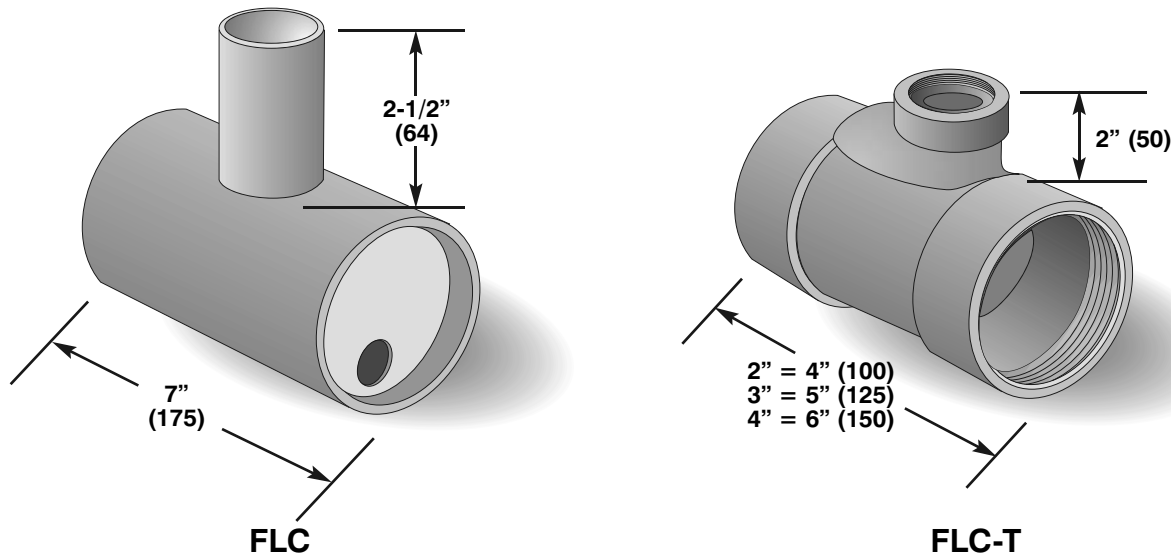

(DIMENSION) DENOTES MILLIMETRES

MODEL NO.	FOR USE WITH MIFAB® INTERCEPTOR	NO HUB PIPE CONNECTION SIZE	ORFICE SIZE	VENT CONNECTION SIZE
FLC-0	MI-G-0	2" (50)	.375" (9)	2" (50)
FLC-1	MI-G-1	2" (50)	.500" (13)	2" (50)
FLC-2	MI-G-2	2" (50)	.656" (16)	2" (50)
FLC-3	MI-G-3	2" (50)	.750" (19)	2" (50)
FLC-4	MI-G-4	3" (75)	1.000" (25)	2" (50)
FLC-5	MI-G-5	3" (75)	1.250" (31)	2" (50)
FLC-6	MI-G-6	3" (75)	1.250" (31)	2" (50)
FLC-7	MI-G-7	3" (75)	2.000" (50)	2" (50)

MODEL NO.	FOR USE WITH MIFAB® INTERCEPTOR	I.P.S PIPE CONNECTION SIZE	ORFICE SIZE	VENT CONNECTION SIZE
FLC-T-0	MI-G-0	2" (50)	.375" (9)	2" (50)
FLC-T-1	MI-G-1	2" (50)	.500" (13)	2" (50)
FLC-T-2	MI-G-2	2" (50)	.656" (16)	2" (50)
FLC-T-3	MI-G-3	2" (50)	.750" (19)	2" (50)
FLC-T-4	MI-G-4	3" (75)	1.000" (25)	2" (50)
FLC-T-5	MI-G-5	3" (75)	1.250" (31)	2" (50)
FLC-T-6	MI-G-6	3" (75)	1.250" (31)	2" (50)
FLC-T-7	MI-G-7	3" (75)	2.000" (50)	2" (50)

Design and dimensions are subject to modification. Prices do not include applicable taxes. Visit www.mifab.com for the most recent product information.

MIFAB, Inc., 1321 West 119th Street, Chicago, Illinois 60643-5109, USA

Toll Free 1-800-465-2736, Fax 773-341-3049

All sales subject to MIFAB's Terms and Warranties. Please refer to inside front cover.

MIFAB INTERCEPTOR SELECTION GUIDE (Cont'd)

Extensions

Extensions should be specified on grease and oil interceptors when the interceptor is buried into the ground, vertical adjustment of the interceptor is necessary to meet the drainage piping, and/or floor level access is required. Extension heights range from four inches to any maximum practical for serviceability. Extensions in excess of 20" are not recommended. One must consider the slope of the drainage piping from the fixtures to the inlet of the interceptor. Typically, one should allow a slope of $\frac{1}{4}$ " per foot in the drainage pipe. Therefore, there will be many installations, especially with large interceptors, where the sloped drainage pipe ends up below the inlet connection. An extension is added to the top of the interceptor so that the inlet can be lowered to meet the incoming drainage pipe and the lid of the interceptor can be extended to floor level. MIFAB offers three different kinds of extensions: integral, bolt on and cover shrouds. An integral extension is specified by expanding the "C" dimension on the interceptor. The "C" dimension is from the middle of the inlet and outlet to the top of the interceptor. One would specify a "C" dimension to meet the job requirements and the interceptor will be manufactured to that specification. The extension is incorporated into the production of the interceptor to produce a seamless, integral interceptor. A second method of providing an extension is a bolt on design. In this example, a top is manufactured out of the same material as the body. The extension is secured to the body by means of "C lock" devices bearing against its base flange, compressing the sealing gasket to complete the union. The regular lid is bolted to the extension top in the same manner as it would be to the body of a standard interceptor.

Cover Shrouds

In installations where the exact extension dimension required is unknown or where little notice has been provided to the installer advising of the need for an extension; integral and bolt on extensions are impractical due to the time necessary for their fabrication. MIFAB's nationwide network of manufacturer's representatives stock cover shrouds for immediate shipment to jobsites when these situations occur. The cover shroud is adjustable and is recessed into the slab to house the interceptor. Cover shrouds incorporate either standard or draw-off grease interceptors mounted on adjustable elevation cradles in either open or closed bottom housings with non-skid floor level lids. Cover shrouds are particularly important where below floor level installation of draw-off grease interceptors is required, because such models cannot be installed independently with tops at the finished floor level. Specify MIFAB MI-CS Series for use with the MI-G Series grease interceptors and MIFAB MI-CSD Series for use with the MI-G-SD and MI-G-SDH semi-automatic draw off grease interceptors.

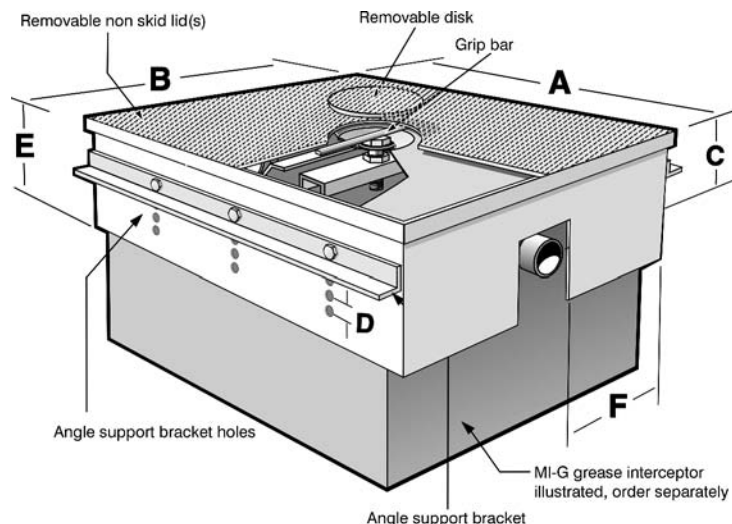

(MI-CS COVER SHROUD ILLUSTRATED)

MIFAB INTERCEPTOR SELECTION GUIDE (Cont'd)

Draw-off valve

All of MIFAB's semi-automatic grease interceptors are manufactured with draw-off valves and are preferred in areas where excessive amounts of grease accumulates because they make the cleaning process easier. The draw-off valve is a gate valve that is connected to the outlet of the interceptor via a pipe nipple. When the accumulated grease is ready to be drawn off, the pipe cap on the top of the interceptor is removed and the draw-off hose is attached with a hose clamp. After warming the interceptor with hot water from the fixture to liquefy the accumulated grease, the draw-off valve is closed to block water escaping through the outlet. Water from the fixture enters at a low flow rate to elevate the liquefied grease into the draw-off pyramid and through the hose to the disposal container. When clear water appears at the hose outlet, the draw-off valve is opened to drop the water level in the interceptor for normal operation. This method of cleaning is more sanitary than the typical manual method. Specify MIFAB Series MI-G-SD, MI-G-SDH and MI-G-L-SDH Series of semi-automatic grease interceptors.

INTERCEPTORS

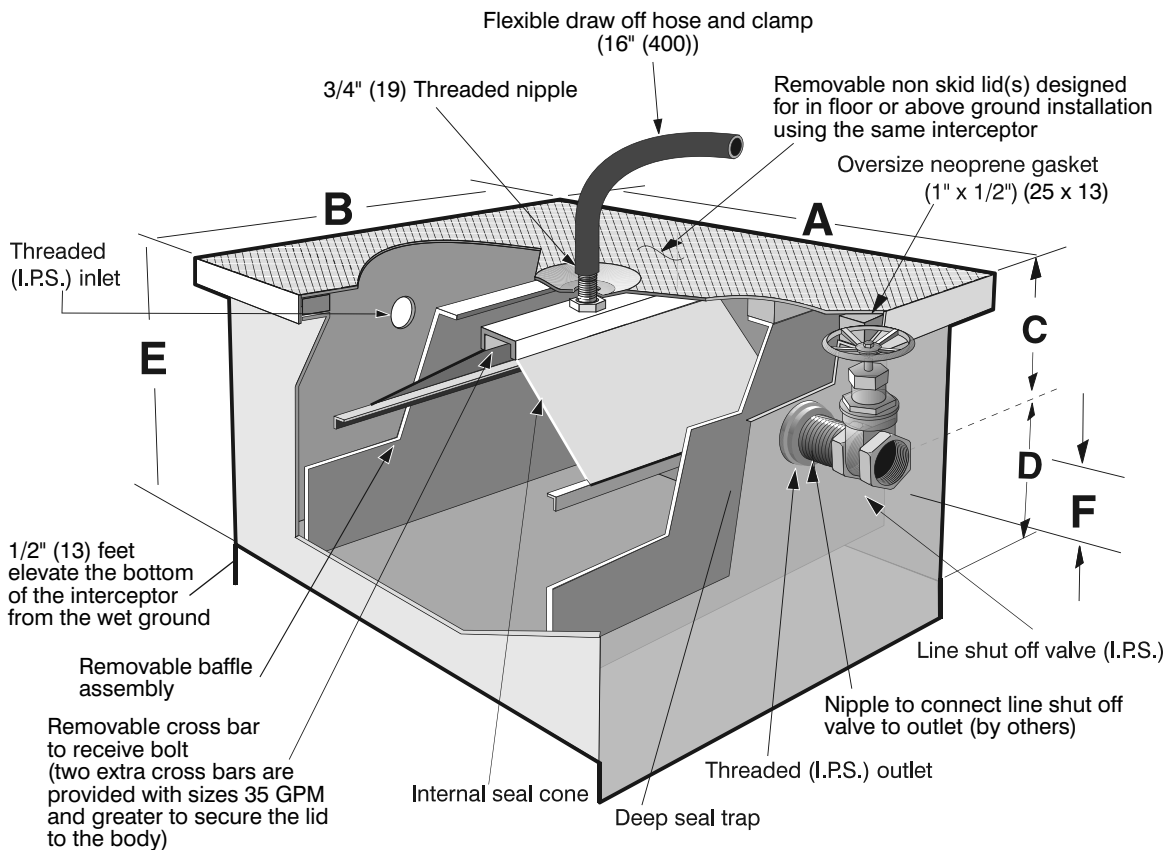

(MI-G-SDH SEMI-AUTOMATIC GREASE INTERCEPTOR ILLUSTRATED)

Design and dimensions are subject to modification. Prices do not include applicable taxes. Visit www.mifab.com for the most recent product information.

MIFAB, Inc., 1321 West 119th Street, Chicago, Illinois 60643-5109, USA

Toll Free 1-800-465-2736, Fax 773-341-3049

All sales subject to MIFAB's Terms and Warranties. Please refer to inside front cover.

MIFAB GREASE INTERCEPTOR INSTALLATION AND MAINTENANCE GUIDE

Installation Diagrams

Figures A2.5.1 through A2.5.5 are included to illustrate various grease interceptor installations normally encountered in domestic, commercial and institutional systems. These figures will serve as a guide to practical application of grease interceptors.

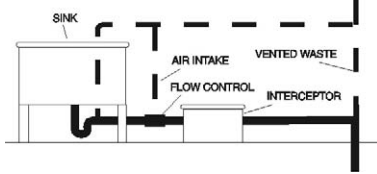

Fig. A2.5.1 Interceptor Serving Trapped and Vented Sink - Flow Control Air Intake Intersects Vent

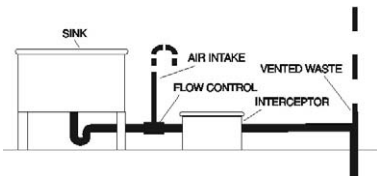

Fig. A2.5.2 Interceptor Serving Sink - Flow Control Air Intake Terminates in a Return Bend Above Flood Level

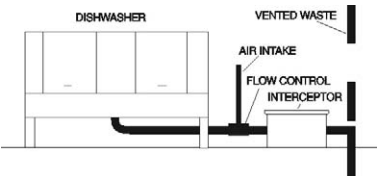

Fig. A2.5.3 Interceptor Serving Dishwasher - Flow Control Air Intake Terminates Above Flood Level

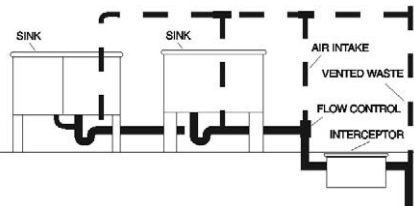

Fig. A2.5.4 Interceptor Serving Two Individually Trapped and Vented Sinks - Flow Control Air Intake Intersects Vent

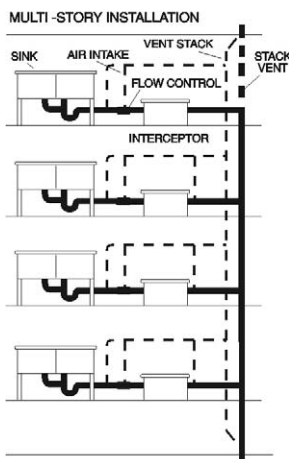

Fig. A2.5.5 Interceptor Serving Trapped and Vented Sinks - Flow Control Air Intakes Intersect Vent

Design and dimensions are subject to modification. Prices do not include applicable taxes.

Visit www.mifab.com for the most recent product information.

MIFAB, Inc., 1321 West 119th Street, Chicago, Illinois 60643-5109, USA

Toll Free 1-800-465-2736, Fax 773-341-3049

All sales subject to MIFAB's Terms and Warranties. Please refer to inside front cover.

INSTALLATION CONSIDERATIONS

Install interceptor as close as practical to fixture or fixtures being served, see figures A2.5.1 through A2.5.5. The interceptor may be set on the floor, partially recessed in the floor, with top flush with the floor, or fully recessed below the floor to suit piping and structural conditions.

Anticipate sufficient clearance for removal of interceptor cover for cleaning. Avoid installation wherein long runs of pipe (exceeding 25 feet (7500)) are necessary to reach interceptor. This precaution will preclude the possibility of pipeline becoming clogged with congealed grease that will collect before reaching the grease interceptor.

Do not install grease interceptor in waste line from garbage grinder. Garbage grinder waste must by-pass interceptor, for rapid accumulation of solid matter will greatly reduce grease interceptor efficiency preventing operation in compliance with rated capacity.

FLOW CONTROL

The flow control fitting furnished with PDI certified interceptors must be installed ahead of interceptor in the waste line beyond the last connection from the fixture and as close as possible to the underside of lowest fixture. When waste of two or more sinks or fixtures are combined to be served by one interceptor, a single flow control fitting should be used. Air intake for flow control may terminate under sink drain board as high as possible to prevent overflow or terminate in a return bend at the same height and on outside of building. When fixture is individually trapped and back-vented, air intake may intersect vent stack. All installation recommendations subject to approval of code authority.

VENTING

Grease interceptors must have a vented waste, sized in accordance with code requirements for venting traps to retain water seal and prevent siphoning.

MULTIPLE FIXTURE INSTALLATION

One interceptor to serve multiple fixtures is recommended only where fixtures are located close together. In such installations, each fixture should be individually trapped and back-vented.

MAINTENANCE

GENERAL CONSIDERATIONS

To obtain optimum operating efficiency of a properly sized and installed PDI certified grease interceptor, a regular schedule of maintenance must be adhered to. All PDI certified grease interceptors are furnished with manufacturer's operating and maintenance instructions, which must be followed to insure efficient satisfactory operation.

CLEANING

All grease interceptors must be cleaned regularly. The frequency of grease removal is dependent upon the capacity of the interceptor and the quantity of grease in the waste water. Grease removal intervals may therefore vary from once a week to once in several weeks. When the grease removal interval has been determined for a specific installation, regular cleaning at that interval is necessary to maintain the rated efficiency of the interceptor. After the accumulated grease and waste material has been removed, the interceptor should be thoroughly checked to make certain that inlet, outlet and air relief ports are clear of obstructions.

DISPOSITION OF INTERCEPTED MATERIALS

Grease and other waste matter that has been removed from the interceptor should not be introduced into any drain, sewer, or natural body of water. This waste matter should be placed in proper containers for disposal. Where recovery of grease is desired, it can be handled in a manner suitable to the authorities.

MIFAB INTERCEPTOR SELECTION GUIDE (Cont'd)

Dishwashers

A separate grease interceptor is recommended for each commercial dishwasher. The size of the interceptor is determined by the GPM discharge rate of the dishwasher as specified by the manufacturer.

Floor Drains

Many local plumbing inspectors require that grease laden wastewater flowing into floor drains must flow through a grease interceptor before draining into the sanitary sewer system. In these instances, the flow control fitting must be installed underground, before the inlet to the interceptor, to moderate the flow from the floor drains and to ensure maximum performance. Consideration should be given to providing access to the flow control fitting in these installations for proper cleaning and maintenance. The MIFAB MI-CSD extended cover shroud is best used in these situations because it is long enough to house the grease interceptor and the flow control fitting beside the inlet. A hole can be cut into the lid of the cover shroud to allow the vent piping to connect to the top of the flow control fitting.

Solids interceptors

The interception and retention of solids cannot be overlooked. Materials such as lint, hair, grindings, ceramic waste, plaster, dental wastes, aquarium and other small gravel, jewels and precious metals are a few solids that should pass through a solids interceptor before entering the waste drain line. Deleterious solids should be intercepted to prevent clogging of the drainage lines and valuable materials require interception for retrieval. MIFAB manufactures a complete line of solids interceptors designed to handle any waterborne solids. Most often these interceptors replace the standard traps of the fixtures they serve. The solids interceptor with a low inlet and high outlet becomes the fixture trap. Solids interceptors are manufactured with easily removable strainers or sediment baskets that serve to retain the intercepted solids while allowing water to flow through. It is good engineering practice to specify a solids interceptor immediately before a grease interceptor so that all debris and solid wastes are caught in the solids interceptor before they enter the grease interceptor. This will ensure that the grease interceptor is not filled as quickly with solid wastes that will only impair its efficiency. In addition, most foul odors from grease interceptors are from rotting solids, not from the grease itself. Proper separation of these solids will reduce the odor problem typically experienced with grease interceptors filled with rotting solids. See MIFAB's MI-SOLID, MI-LINT, MI-HAIR and MI-FISH Series of solids interceptors.

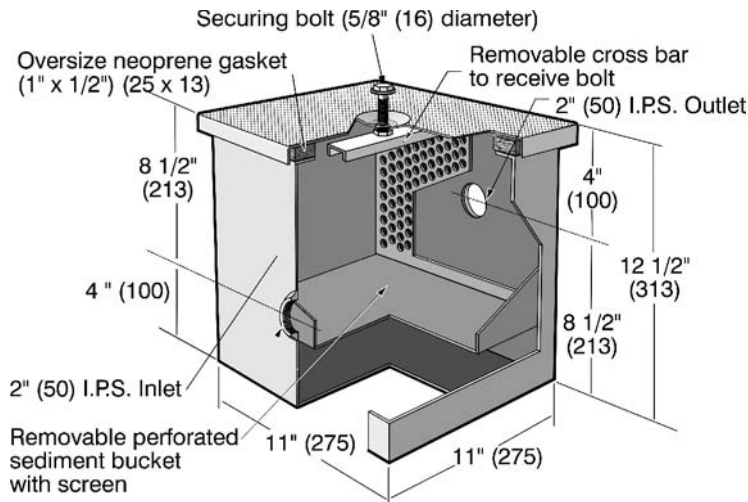

(MI-SOLID-M ILLUSTRATED)

Design and dimensions are subject to modification. Prices do not include applicable taxes. Visit www.mifab.com for the most recent product information.

MIFAB, Inc., 1321 West 119th Street, Chicago, Illinois 60643-5109, USA

Toll Free 1-800-465-2736, Fax 773-341-3049

All sales subject to MIFAB's Terms and Warranties. Please refer to inside front cover.

INTERCEPTORS

MIFAB OIL INTERCEPTOR SELECTION GUIDE

APPLICATION:

MIFAB® oil interceptors are designed for use in drain lines where oils, sediment and other volatile liquids are found. These drain lines may be from areas in parking garages, machine shops, service stations, aircraft hangars, industrial and manufacturing facilities.

DESIGN:

MIFAB® oil interceptors are designed to protect against water pollution by preventing oils and sediment in waste water from entering drain lines. The design allows intercepted oils to be drawn-off automatically for storage continuously during operation. Sediment should be removed from the interceptor at regular intervals.

SIZING:

1. Determine maximum volume of waste water in G.P.M. or L.P.M., by summing volumes of all discharging fixtures that may enter the drain lines at one time.
2. Select oil interceptor with flow rating equal to peak volume in G.P.M. or L.P.M. (see table on shop drawing.) Provide storage tank capable of handling the volume.

TYPICAL CODE REGULATIONS

Vehicle servicing. When an oil interceptor is installed in an automobile, truck, bus, or tractor garage or in a service station or repair shop with facilities for motor or transmission overhauling, it must have a minimum static water depth of 24 inches (600) below the invert of the interceptor outlet and a minimum static water capacity of 6 cubic feet.

This regulation applies to facilities where not more than three vehicles are serviced. For each additional vehicle up to and including ten, 1 cubic foot of static capacity shall be added. For each vehicle over ten, an additional 0.25 cubic foot shall be added.

Vehicle storage and servicing. Where motor vehicles are serviced and stored, an oil interceptor shall be installed with a static water capacity of 1 cubic foot for every 100 square feet of area to be drained. The oil interceptor shall have a minimum static water level of 6 cubic feet.

Mechanical car washing. In facilities designed especially for mechanical washing of motor vehicles, a sand and gravel interceptor shall be installed to receive the waste water from all washing facilities. A minimum static water level of 2.5 feet and a minimum static water capacity of 50 cubic feet shall be maintained.

Where motor cleaning services are rendered at mechanical car washing facilities, an oil interceptor shall be installed in that section of the drainage system which receives waste water from this operation.

Vehicle storage. In motor vehicle storage facilities, a combination interceptor-drain shall be installed with a static water level of 1 gallon for every 100 square feet of area to be drained.

Manual car washing. In a one-car washing facility, a combination interceptor-drain shall be installed with a minimum static water capacity of 30 gallons.

OIL DRAW-OFF

Oil draw-off funnel is adjustable to the gravity height of oil and gallon per minute flow. It leads in to oil discharge pipe, from which suitable disposal of oil can be made in the most economical way.

After interceptor is installed, establish operating water level by running water through interceptor at maximum flow rate expected. Adjust vertical draw-off pipe 1/8" (3) to 1/4" (6) above water line. Periodic checking of this level after interceptor is in operation will assure proper functioning of the oil draw-off. If drawn off oil contains any water, raise vertical draw-off pipe until only oil flows from interceptor.

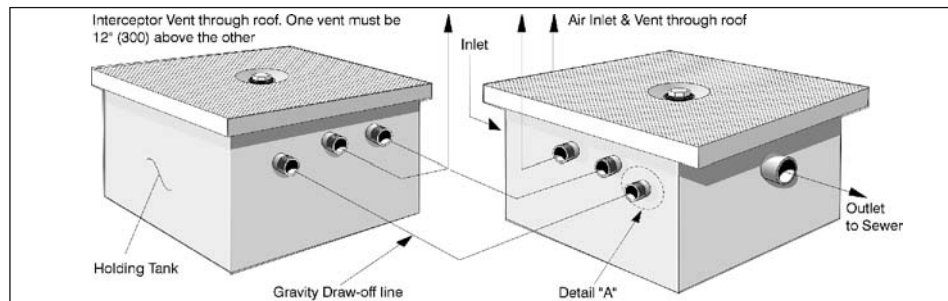

GRAVITY OIL DRAW-OFF

DRAW-OFF CONNECTIONS

Connect to Holding Tank which must be vented

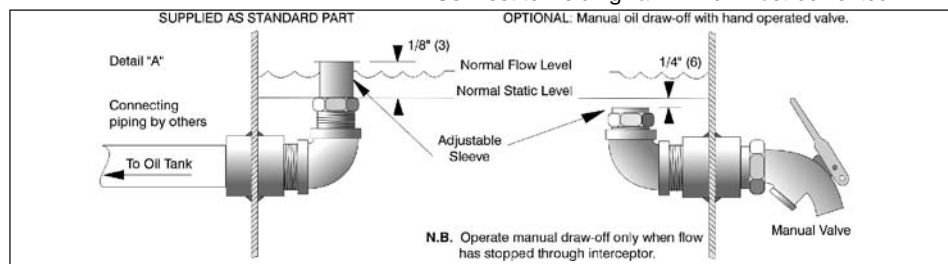

(Dimension) Denotes Millimetres

Design and dimensions are subject to modification. Prices do not include applicable taxes.

Visit www.mifab.com for the most recent product information.

MIFAB, Inc., 1321 West 119th Street, Chicago, Illinois 60643-5109, USA

Toll Free 1-800-465-2736, Fax 773-341-3049

All sales subject to MIFAB's Terms and Warranties. Please refer to inside front cover.